

# CP5500 RANGE INFORMATION & CP5500-605 / -505 DIFFERENCES



## CP5500, 3 Pedal, Push Type Floor Mounted Pedal Box

CP5500-605 is an updated three pedal box assembly. CP5500-605MTS & UTS versions include a new contact less rotary sensor with dual input/output for redundancy and a stronger throttle spring to suit.

CP5500-605M & U are available without throttle sensor fitted. (Fig 1. Depicts the main difference between -605 & -505 types).

**CP5500-605** will replace **CP5500-505** which will be made inactive in the near future once existing stocks have been exhaust but continues to include all the similar features its predecessor benefited from. See attached installations drawing for details.

A complete part number and supercession guide to CP5500 range is below.

<b>CP5500 Pedal Box Range</b>					
<b>Available Part No's &amp; Description.</b>	<b>Clevis Threads</b>		<b>Throttle Sensor</b>		<b>Replaces Pedal Box Part number</b>
	<b>Metric - M8x1.25</b>	<b>Imperial - 5/16" UNF</b>	<b>Included</b>	<b>Not Included</b>	
<b>Three Pedal Assemblies (Brake, Clutch &amp; Throttle).</b>					
CP5500-605MTS	✓	✗	✓	✗	<b>CP5500-505MET</b>
CP5500-605M	✓	✗	✗	✓	<b>CP5500-505MET</b>
CP5500-605UTS	✗	✓	✓	✗	<b>CP5500-505UNF</b>
CP5500-605U	✗	✓	✗	✓	<b>CP5500-505UNF</b>
<b>Two Pedal Assembly (Brake and Clutch).</b>					
CP5500-515MET	✓	✗	✗	✗	No Change
CP5500-515UNF	✗	✓	✗	✗	No Change
<b>Single Brake Pedal Assembly.</b>					
CP5500-535MET	✓	✗	✗	✗	No Change
CP5500-535UNF	✗	✓	✗	✗	No Change
<b>THE FOLLOWING CP5500 PART NUMBERS ARE NOW INACTIVE</b>					
Brake & Throttle Assembly - CP5500-525MET & UNF				No Replacement.	
Clutch Pedal Assembly - CP5500-545MET & UNF				No Replacement.	

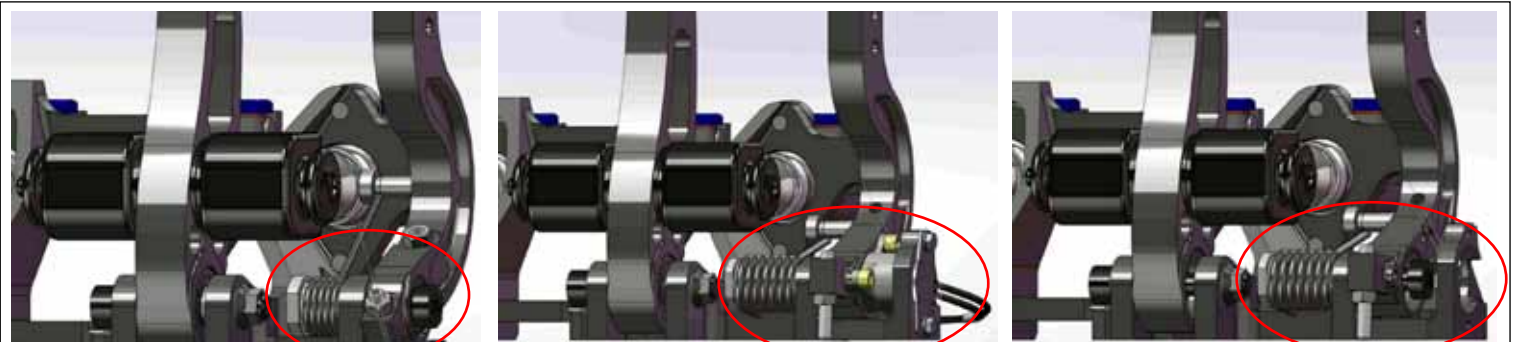

**CP5500-505MET or UNF**  
- No longer available -

**CP5500-605MTS or UTS**  
- With Throttle Sensor -

**CP5500-605M or U**  
- Without Throttle Sensor -

Fig 1.